



ENERMAX
POWER. INNOVATION. DESIGN.



EMB550AWT

MARBLEBRON

MARBLEBRON



- *Semi-modular Design with Black Flat Cables*
- *80 PLUS® Bronze Certification*
- *Using Japanese Electrolytic Capacitors*
- *Introducing Into DC to DC Circuit*
- *120mm High Pressure fan with SAC Design*



Features

- **Easy Installation**
 - Semi-modular design
 - Flexible black flat cables for both of native and modular ones
- **Energy Conservation**
 - 80 PLUS® Bronze certification with 90% efficiency @50% load
 - Efficient +5Vsb circuitry consume only under 0.5W at standby mode
 - Active PFC design with PF value up to 0.99
- **Longer Product Lifespan**
 - Using Japanese electrolytic capacitors
- **Great Using Experience**
 - Introducing into DC to DC circuit
 - Equipped with 120mm high pressure fan
 - Introduce into SAC (Smart Air Control) design
 - High-end components and advanced layout bring industrial performance
- **User Friendly**
 - Single rail +12V design
 - 100-240VAC auto-adjustment input for universal use
- **Safety**
 - Multiple protection circuitries of OVP, UVP, OPP, SCP and OTP



Semi-modular Design



Flexible Flat Cable Design

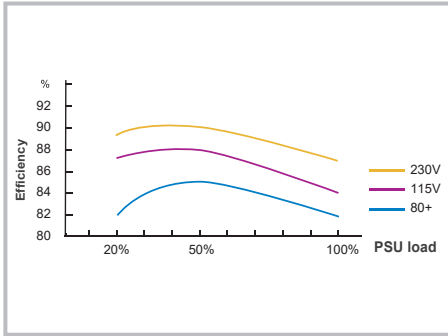

80 PLUS® Bronze Certification

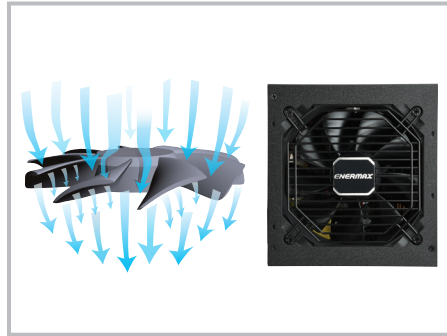

120mm High Pressure Fan

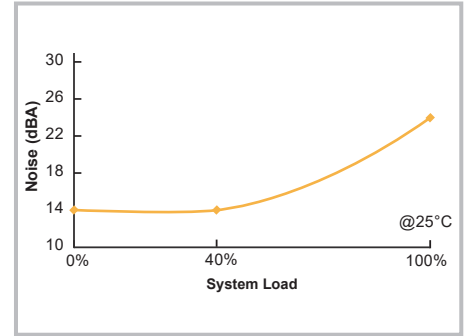

SAC(Smart Air Control) Design

Dimension

Unit : mm

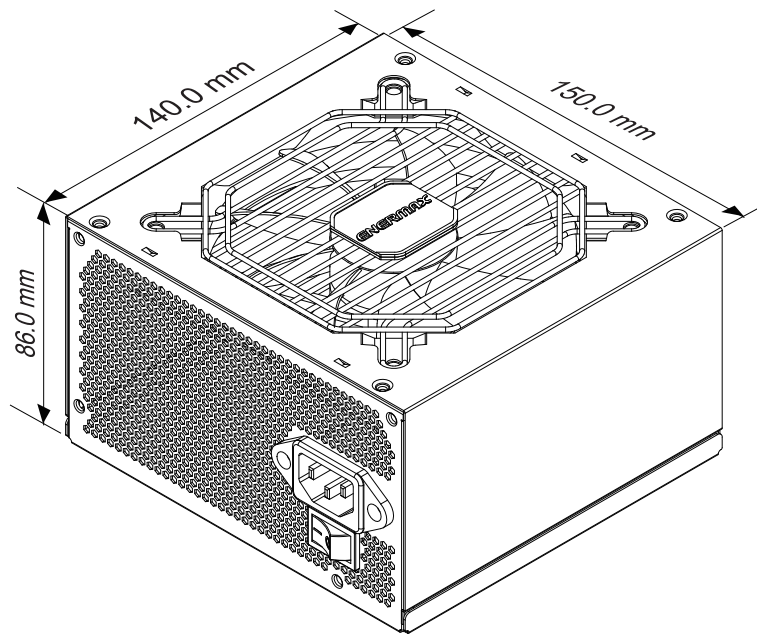

Cables & Connectors

Model	Native Cables			Modular Cables		
	Mainboard 24P	CPU 4+4P (8P)	PCI-E 6+2P (8P)	SATA	4P Molex	FDD (adapter)
750W	1	2	4	8	4	1
650W	1	1	4	8	4	1
550W	1	1	2	6	4	1

Specifications

Model	EMB550AWT		EMB650AWT		EMB750EWT	
AC Input Voltage	100-240VAC, 47-63Hz					
AC Input Current	8-4A		10-5A		11-5.5A	
DC Output						
	Rated	Combined	Rated	Combined	Rated	Combined
+3.3V	20A	110W	20A	120W	20A	130W
+5V	20A		20A		20A	
+12V1	45A	540W	54A	648W	62A	744W
-12V	0.3A	3.6W	0.3A	3.6W	0.3A	3.6W
+5Vsb	2.5A	12.5W	2.5A	12.5W	2.5A	12.5W
Total Power	550W		650W		750W	
Dimensions	150(W) x 86(H) x 140(D)mm					



Logistic Information

Model		EMB550AWT	EMB650AWT	EMB750EWT
Bar code	EAN	4713157724977	4713157724984	4713157724991
	UPC	819315024973	819315024980	819315024997
Box Dimension		248 x 211 x 95 mm		
Gross Weight / Unit		1.94kgs	2.16kgs	2.28kgs
Carton Dimension		495 x 263 x 231 mm		
Q'ty / Carton		5pcs		
Gross Weight / Carton		10.2kgs	11.3kgs	11.9kgs