

LIQMAX II 120S

ALL-IN-ONE LIQUID CPU COOLER





- 320W+ TDP
- Shunt Channel Technology cold plate
- Gen. 2 Batwing fans

LIQMAX II 120S features a new cooling block with advanced impellers, ENERMAX patented Shunt Channel Technology (S.C.T) and the 2nd generation batwing fans with patented APS(Adjustable Peak Speed) triple RPM range setting function. LIQMAX II 120S offers 320W+ cooling capacity.



Shunt-Channel-Technology



3 Cooling modes



Batwing blades fan



Easy-installation bracket

Features

- Patented Shunt-Channel-Technology (SCT) boosts thermal conductivity and eliminates any heat surge**

Enermax patented SCT (Shunt-Channel-Technology) design enables the cold plate to eliminate the "Boundary Layer" to increase coolant flow momentum and accelerate heat transfer performance. The SCT also let the heated and non-heated coolant to swap the channel and increase utilization rate.

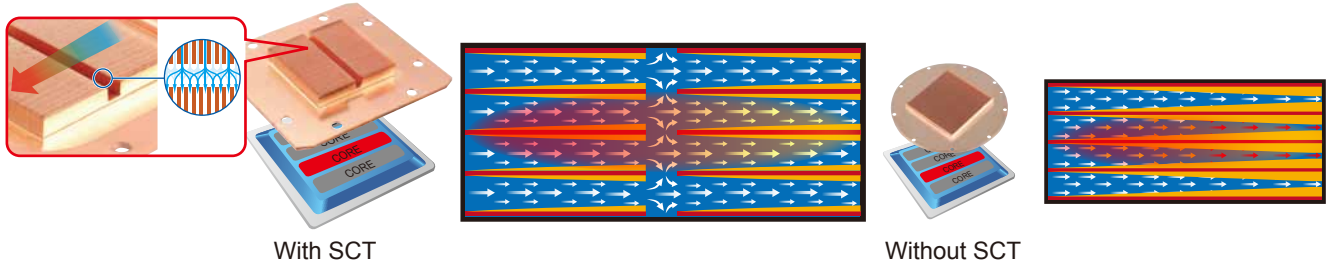

- Advanced impeller increases pump pressure and flow momentum performance to provide smooth coolant circulation**

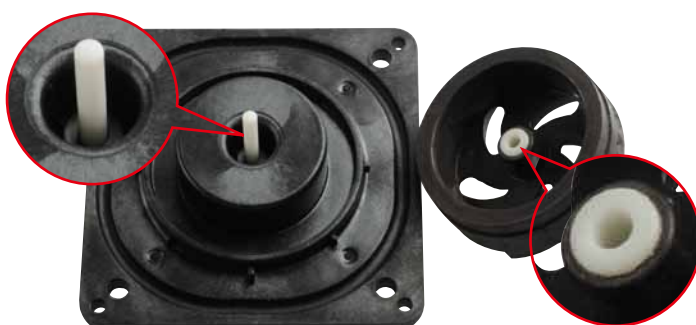

- Ceramic bearing pump provides exceptional durability and noiseless operation**

- 27mm depth slim radiator offer great system compatibility



- The 2nd generation Batwing blades fan creates continuous burst air flow to penetrate the radiator and dissipate the heat efficiently



Enermax Gen.2 Batwing blade: Burst airflow



Conventional design

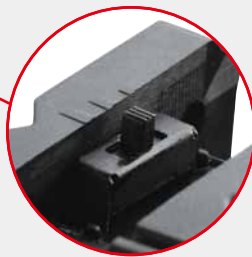

- 3-Cooling modes:
 - *Silence mode: 500-1200 rpm
 - *Performance mode: 500-1600 rpm
 - *Overclocking mode: 500-2000 rpm

- Patented APS (Adjustable peak speed) control provides 3 peak rpm options

The patented APS (Adjustable peak speed) let the user choose the preferred fan speed modes (Silent / Performance / Overclocking) depending on the system application by simply slide the small switch at the fan frame.

- Anti-vibration rubber pads provide noiseless stable operation



- Durable and flexible rubber tubes ensure zero permeability

- Easy-installation bracket with pressure adjustment spring screws ensures perfect contact force with CPU



Dimensions

unit:mm

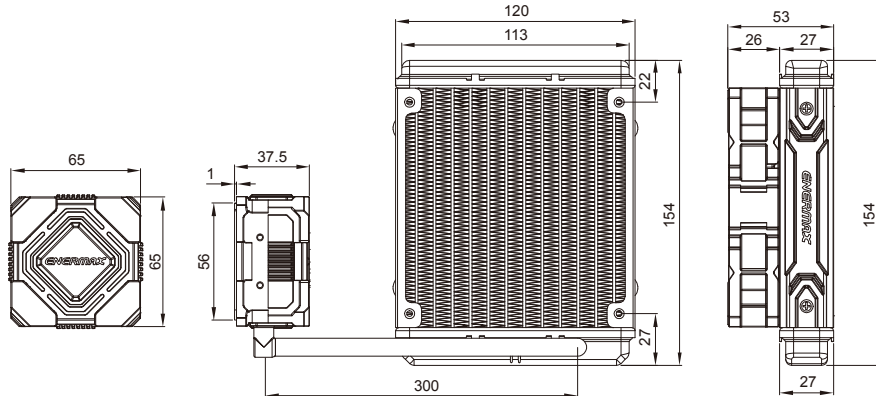

*Some MB put the capacitors around the boarder of CPU bracket, please carefully install the cooler on can avoid the mechanical interference.

Specifications

Model Name		ELC-LMR120S-BS
Cold Plate	Material	Copper
Pump	Bearing	Ceramic Bearing
	MTBF	50,000 hrs
	Motor Speed	2700 rpm \pm 10%
	Rated Voltage	12 V
	Rated Current	0.3 A
Radiator	Dimension	154 x 120 x 27 mm
	Material	Aluminum
Tube	Material	Rubber
	Length	300 mm
Weight (w/o fan)		580 g
Bracket	Compatibility	Intel® LGA 775/1150/1151/1155/1156/1366/2011/2011-3 AMD® AM2/AM2+/AM3/AM3+/FM1/FM2/FM2+
Fan	Dimension	120 x 120 x 25 mm
	Speed	500-1200/1600/2000 rpm \pm 10%
	Rated Voltage	12 V
	Rated Current	0.09/0.19/0.38 A
	Air Flow	27.7~58.3/75.5/96.0 CFM 47.1~99.1/128.3/163.1 m ³ /h
	Static Pressure	0.4~1.3/2.4/3.0 mm-H ₂ O
	Noise Level	16~23/30/35 dBA
	Connector	4 pin PWM